

# MASABA



PORTS & TERMINALS

[www.masabainc.com](http://www.masabainc.com) | 877-627-2220



## Ports & Terminals

Masaba provides leading edge technology in bulk material handling and custom engineered solutions. Our patented Magnum telescoping radial stackers and drive over truck unloaders provide maximum production rates and minimizes labor on site.

Eliminate double handling of material and easily load barges and vessels with Masaba's portable material handling equipment.





# Ports & Terminals

## PAIRED FOR MAXIMUM PERFORMANCE

Pair Masaba's Truck Unloader with our RUGGED Magnum Telescoping Conveyor for customizable automation to maximize your output and performance. Our custom configurations offer the mobility needed for ship loading systems, providing significant cost savings and flexibility over a permanent, fixed system. Masaba has YOUR solution!



# MAGNUM

TELESCOPING CONVEYOR



## Magnum Telescoping Radial Stacker

### THE MOST RUGGED TELESCOPING CONVEYOR IN THE WORLD

Masaba's Magnum Telescoping Conveyor is the safest, most rugged telescoping conveyor on the market. Our patented design provides constant engagement and smoother operation of the stinger, improving long term durability and minimizing required maintenance.

Ranging from 100 feet to 195 feet, we have a Magnum to suit your needs. Custom solutions are our strong suit. If one of our standard Magnums does not suit your need, we will custom engineer one for you.

### WORLD-CLASS AUTOMATION

Masaba's Programmable Logic Control (PLC) with large color touchscreen HMI provides easy interaction and high visibility. The PLC, in conjunction with variable speed wheel drives, creates the highest quality desegregated piles. Three encoders work with the PLC to accurately locate X, Y, and Z locations of the head pulley. Four customizable programs enable users to choose their stockpile preference.



# MASABA'S PATENTED TRACK DRIVES



- Masaba's patented designs provide constant engagement and smoother operation of the stinger, improving long term durability and minimizing required maintenance.
- No cable maintenance issues associated with winch systems - eliminates danger of cable breakage and uncontrolled rollback.
- Masaba's load roller supports assure equal load distribution on all support rollers, minimizing fatigue stress on critical components.

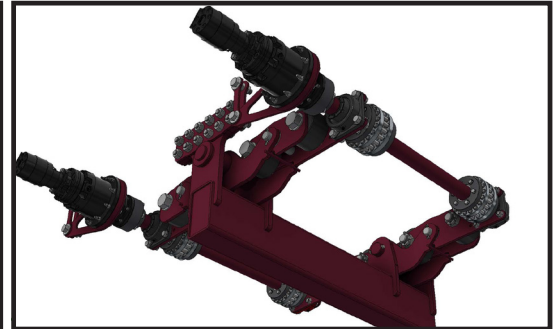

SINGLE DRIVE
Single Gearbox with Mechanical Brake
QD Bushed Pin Hubs w/ Hardened Pins
Keyed & Press Fit Gearbox Connection
Four Maintenance Free Support Rollers

DUAL DRIVE
Dual Gearbox with Dual Mechanical Brakes
QD Bushed Pin Hubs w/ Hardened Pins
Keyed & Press Fit Gearbox Connection
Eight Maintenance Free Support Rollers



# AXLE/DRIVE UNDERCARRIAGE OPTIONS

Masaba offers multiple axle drive system configurations to suit your needs in the field.

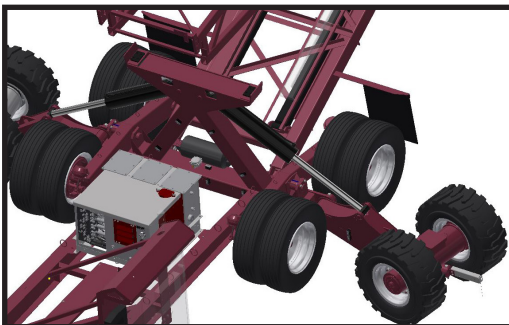

Folding Axle

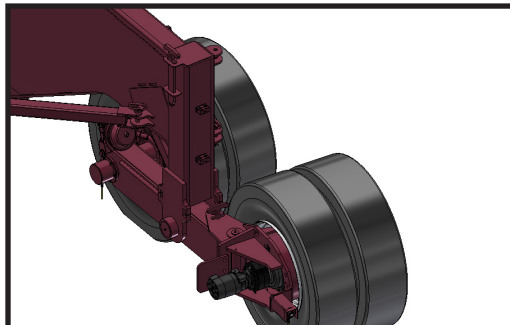

Swing Axle with Hydra Shift

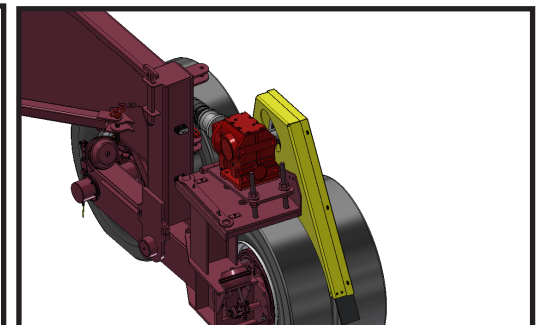

Swing Axle with Chain & Sprocket Drive

**Masaba's Folding Axle (FA)** allows for easy transition between operation and transport positions. Both axles can be hydraulically raised or lowered independently or at the same time, simplifying the leveling process. FA axles are available in both 2 and 4-wheel drive models.

**The Hydra Shift** option simplifies the setup process and reduces maintenance time by removing the chain and sprockets. Hydra Shift allows the operator to engage and disengage the drive simply by flipping a lever on the hub.

**The Swing Axle (SA)** system provides the widest and most stable radial footprint in the industry. A Variable Speed wheel drive allows for even distribution of material in-pile for fully desegregated stockpiles. An optional 4-wheel drive system ensures positive traction in the field.

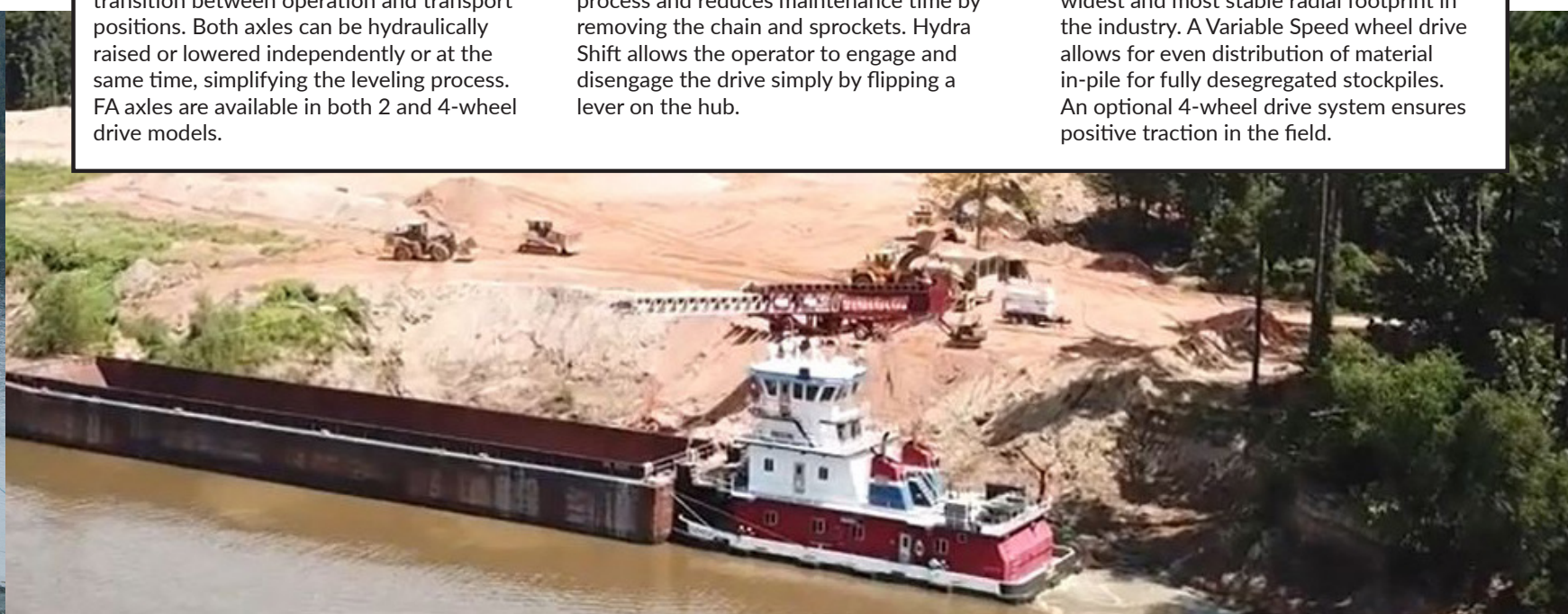



**High Profile**



**Low Profile**

<b>MAGNUM STANDARD CONFIGURATIONS - LOW PROFILE W/FOLDING AXLE</b>							
Conveyor Length	100'	110'	130'	140'	150'		
Belt Width (Inches)	36	36	36	36	30	36	42
Capacity (TPH)	800	800	1000	1000	500	1000	1500
<b>Operational Dimensions</b>							
Max Discharge Height	33' 6"	40' 6"	41' 8"	43'	46' 3"	46' 3"	46' 3"
<b>Pile Volume in Tons (@100 PCF)</b>							
90°	12,900	18,400	28,800	37,200	46,600	46,600	46,600
180°	23,100	32,900	51,600	66,500	83,400	83,400	83,400
270°	33,400	47,500	74,400	95,900	120,100	120,100	120,100

LPFA = Low Profile Fold Axle LPSA = Low Profile Swing Axle HPSA = High Profile Swing Axle

Tugger option available upon request. Pit portable configurations available.

<b>MAGNUM STANDARD CONFIGURATIONS - HIGH PROFILE W/SWING AXLE</b>													
Conveyor Length	130'			150'				170'			190'		
Belt Width (Inches)	36	42	48	30	36	42	48	36	42	48	36	42	48
Capacity (TPH)	1000	1500	2000	800	1000	1500	2000	1000	1500	2000	1000	1500	2000
<b>Operational Dimensions</b>													
Max Extended Discharge Height	47' 8"	47' 6"	49'	52' 4"	52' 4"	51' 4"	51' 6"	60' 7"	57' 9"	58' 3"	63' 11"	66' 5"	66' 5"
<b>Pile Volume in Tons (@100 PCF)</b>													
90°	36,600	36,600	36,700	52,100	52,100	52,100	53,100	73,100	73,100	71,800	104,000	104,000	104,000
180°	65,100	65,100	65,100	92,700	92,600	92,600	94,500	129,800	129,800	127,300	184,800	184,800	184,800
270°	93,500	93,500	93,600	133,200	133,200	133,200	135,900	186,400	186,400	182,700	265,500	265,500	265,500

Custom Magnums Available. Larger belt widths available upon request. Contact us for details.

NOTE: Dimensions will vary based on axle configurations, options, etc. All dimensions are subject to change. For dimensions and drawings of specific models, please contact Masaba at 1-877-627-2220.



## Low Profile Truck Unloaders

Save in labor, fuel and maintenance costs by reducing multiple handling of material with our low profile truck unloaders. Whether you need an unloading system for stationary applications or a completely portable piece of equipment, our engineers will work with you to design the ideal truck unloader for your operation.

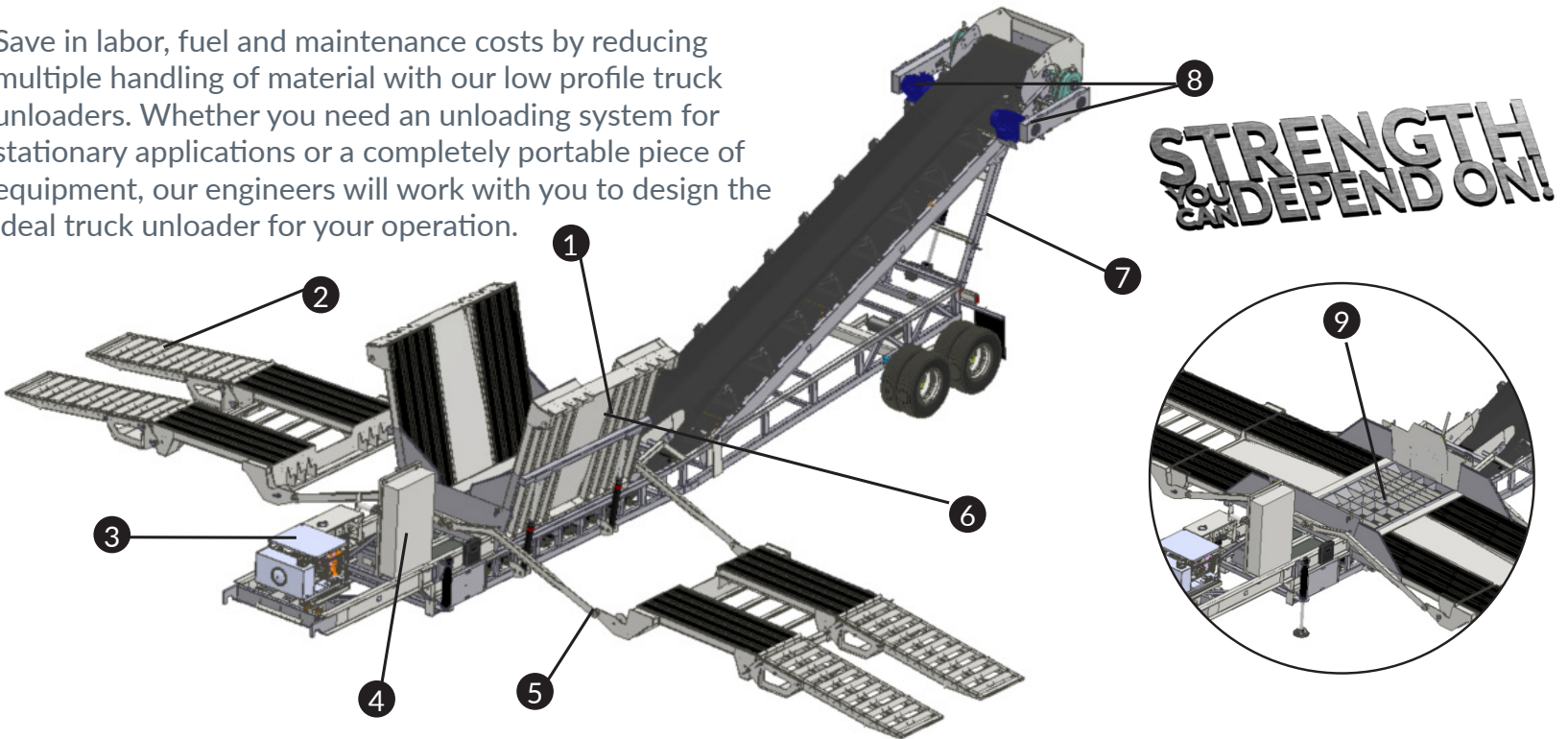

- 1. Self cleaning hydraulic ramps
- 2. Extended ramp option
- 3. Electric auxiliary hydraulic pump
- 4. NEMA 4 control panel
- 5. Optional self-deploying ramps
- 6. Heavy duty steel ramps to grade
- 7. Hydraulically adjustable discharge height
- 8. Class II dual drives
- 9. Removable drive-over grate



**Optional Self-Deploying Ramps**  
Hydraulic system saves you time and steps in deploying the ramps.



**Discharge Hood**  
with AR liners to feed 36" belt width or greater.



**Wireless Remote Control**  
Easily cycle your ramps from the comfort of your cab.

# MASABA

1617 317TH STREET  
PO BOX 345  
VERMILLION, SD 57069



MOVING YOUR BUSINESS  
**FORWARD**

Find your official **MASABA** dealer on-line at: [www.masabainc.com/find-a-dealer](http://www.masabainc.com/find-a-dealer) or scan this QR code:

#### Masaba Corporate Headquarters

1617 317th Street | PO Box 345  
Vermillion, SD 57069  
Toll Free: 877-627-2220  
Direct: 605-624-9555  
Fax: 605-624-9555

#### Masaba Canada

827501 Grey Rd. 40  
Blue Mountains, Ontario N0H 1J0  
Phone: 519-599-3100  
Fax: 519-599-0999



[www.facebook.com/MasabaMining](http://www.facebook.com/MasabaMining)



[www.youtube.com/MasabaMining](http://www.youtube.com/MasabaMining)



[www.linkedin.com/company/masaba-inc.](http://www.linkedin.com/company/masaba-inc.)

