



10 YARD SAND WAGON



FEATURES:

- » Main Frame – constructed of Heavy Duty steel tube with cross tube supports
- » Single Axle – with (4) 225 – 70 – 22.5 tires
- » Road Portable Package
- » Crank down landing jack at king pin end of chassis
- » Bumper mounted on rear, heavy tube steel constructed
- » Hopper/Feed Conveyor
- » Main Frame – Heavy Duty Steel Tube Construction with Cross Tube Supports, ¼” Hopper
- » Hopper – 7’8” x 14’ Opening with Baffle
- » Gate Opening – Manual Operated Feed Gate with Handle extension to operate from side of wagon
- » Feed Conveyor – 13’4” Channel Frame Feed Conveyor
- » Fabricated Access Ladder
- » Slinger Conveyor with Hydraulic Tilt
- » Main Frame – Constructed from 3/8” Formed Plate
- » Motor – Char-Lynn Hydraulic Motor
- » Coupling - Vescor Flexible Coupling
- » Conveyor – Reversible to Allow Throw of up to 15’ in Either Direction
- » Adjustable Tilt – Allows User to Adjust Height and Distance of Throw w/Hydraulic Control

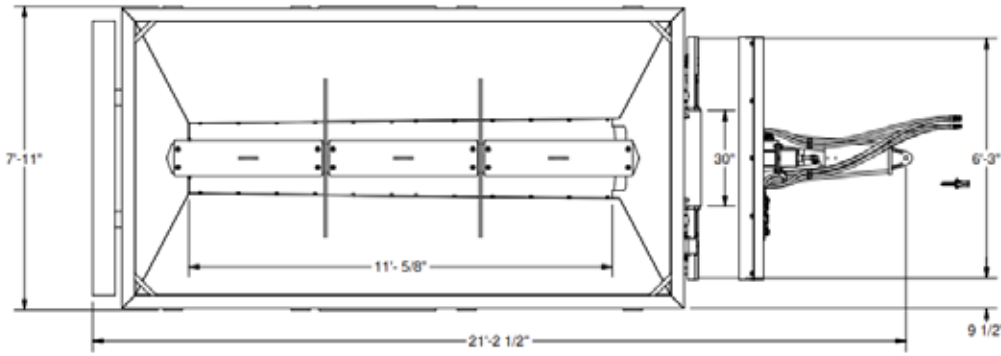

10 YARD SAND WAGON

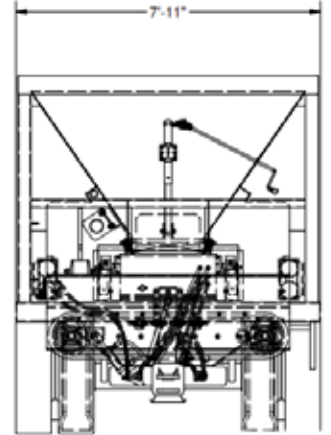
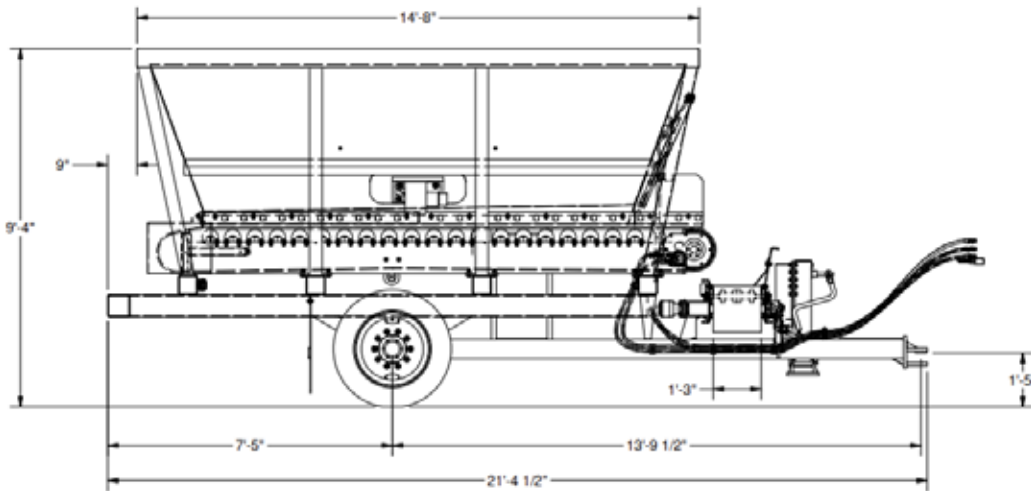

9,500 LBS EMPTY
35,200 LBS LOADED*

1,700 LBS EMPTY
3,000 LBS LOADED*



Contact us to learn more

MASABA

Kevin Glendenning
Regional Sales Manager
608-482-2394
info@masabainc.com

Kevin Glendenning

Regional Sales Manager

MASABA



+1 608 482 2394
mobile



kevin.glendenning@masabainc.com



kevin-glendenning-a724851b8/

